



Fastener
Solutions

Fine Fabric™ System 500™ Fasteners Marketing Specifications

For the following part numbers:

16022-0		GF13N
16023-0	Graphic	GF13W
16024-0		GF13B
16025-0		GF13S
16026-0		
17041-0	Graphic	GF125N
17042-0		GF125W
17043-0		GF125B
		GF125S
	Graphic	GF12N
		GF12W
		GF12B
		GF12S

March 3, 2020

AVERY DENNISON MARKETING SPECIFICATION

HISTORY

THE SUBJECT MATTER DISCLOSED HEREIN EMBODIES PROPRIETARY INFORMATION WHICH IS THE CONFIDENTIAL PROPERTY OF THE AVERY DENNISON CO. NONE OF WHICH SHALL BE COPIED, REPRODUCED, DISCLOSED TO OTHERS, PUBLISHED OR USED IN WHOLE OR IN PART, FOR ANY PURPOSE OTHER THAN THAT FOR WHICH IT IS BEING MADE AVAILABLE WITHOUT THE EXPRESS ADVANCE WRITTEN PERMISSION OF A DULY AUTHORIZED AGENT OF THE COMPANY. THIS DOCUMENT IS THE PROPERTY OF THE AVERY DENNISON CO. AND IS TO BE RETURNED TO THE COMPANY ON DEMAND.

REV.	DATE	DESCRIPTION
A	05.16.17	PRODUCTION RELEASE

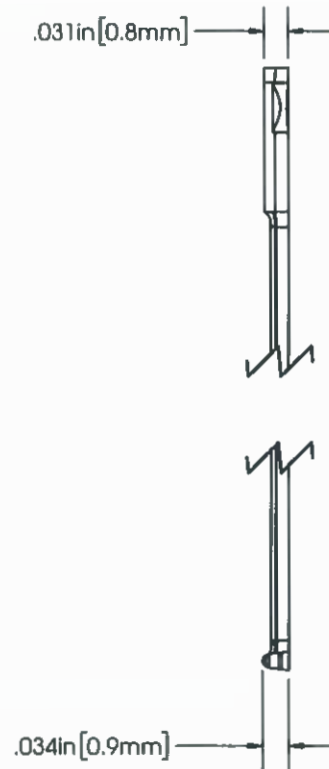
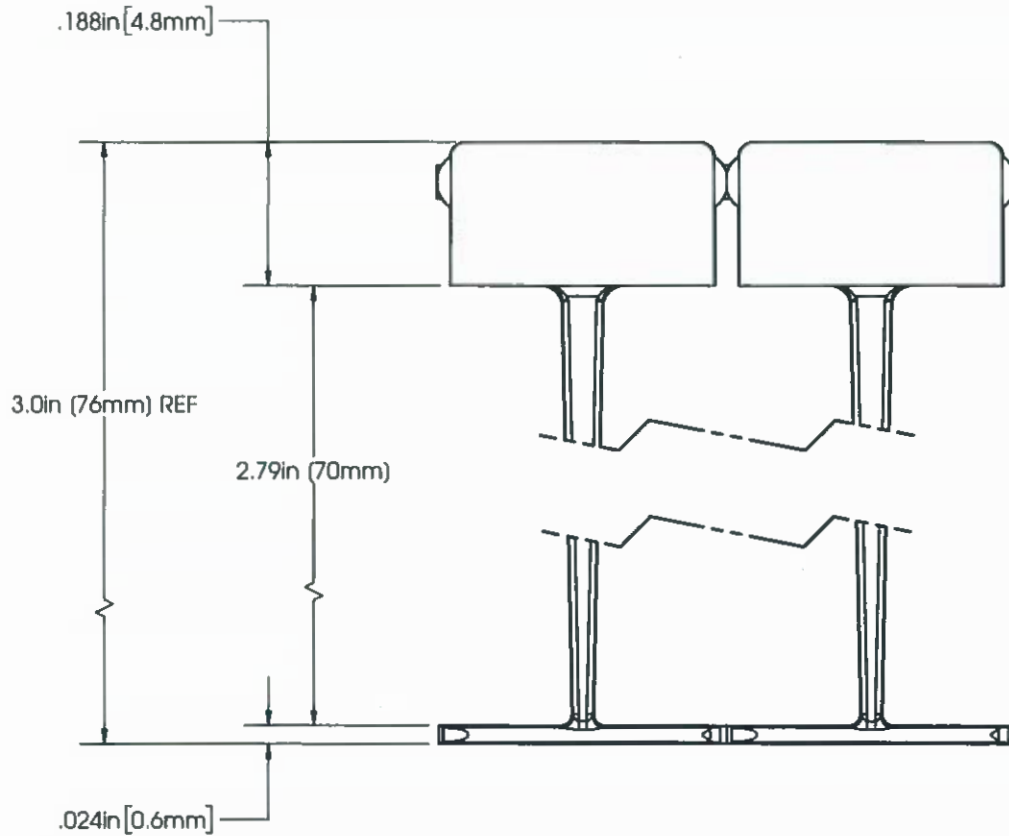

NOT TO SCALE

TENSILE STRENGTH:	2.2 lbf (998 g) MINIMUM	APPROVALS:	ENG. APPR. <i>[Signature]</i> 7-26-2017	 AVERY DENNISON <small>FASTENER DIVISION FITCHBURG, MA 01420 U.S.A. TEL: 1-800-225-5913 FAX: 978-353-8157</small>				
WEIGHT:	.04 GRAMS/EACH		Q.A. APPR. <i>[Signature]</i> 08/01/2017					
PACKAGED:	5000/CTN, 50,000/CASE	SPECIFIED TOLERANCES ARE: .XX ± .03 INCHES .X ± .7 mm .XXX ± .010 INCHES .XX ± .25 mm ANGULAR: ± 2°	MATERIAL	DESCRIPTION				
APPLICATION TOOL:	16010-0 - HAND TOOL <small>(CONTACT SALES SPECIALIST FOR ADDITIONAL OPTIONS)</small>		MATERIAL	POLYPROPYLENE	SYSTEM 500 FF, STD PADDLE, 3 IN			
ROLL QUANTITY	500 FASTENERS		COLOR	NATURAL	STOCK NO.	16022-0	REV.	A

5

4

3

2

1

AVERY DENNISON MARKETING SPECIFICATION

HISTORY

THE SUBJECT MATTER DISCLOSED HEREIN EMBODIES PROPRIETARY INFORMATION WHICH IS THE CONFIDENTIAL PROPERTY OF THE AVERY DENNISON CO. NONE OF WHICH SHALL BE COPIED, REPRODUCED, DISCLOSED TO OTHERS, PUBLISHED OR USED IN WHOLE OR IN PART FOR ANY PURPOSE OTHER THAN THAT FOR WHICH IT IS BEING MADE AVAILABLE WITHOUT THE EXPRESS ADVANCE WRITTEN PERMISSION OF A DULY AUTHORIZED AGENT OF THE COMPANY. THIS DOCUMENT IS THE PROPERTY OF THE AVERY DENNISON CO. AND IS TO BE RETURNED TO THE COMPANY ON DEMAND.

REV.	DATE	DESCRIPTION
A	05.16.17	PRODUCTION RELEASE

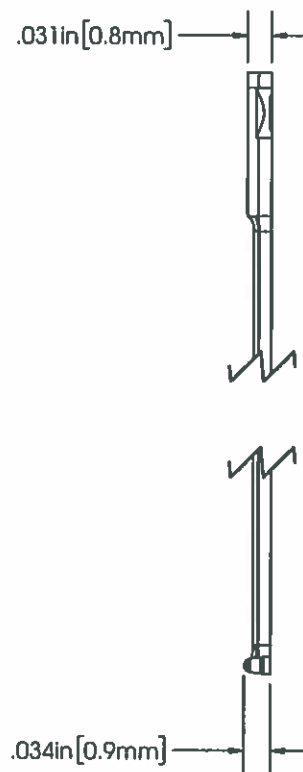
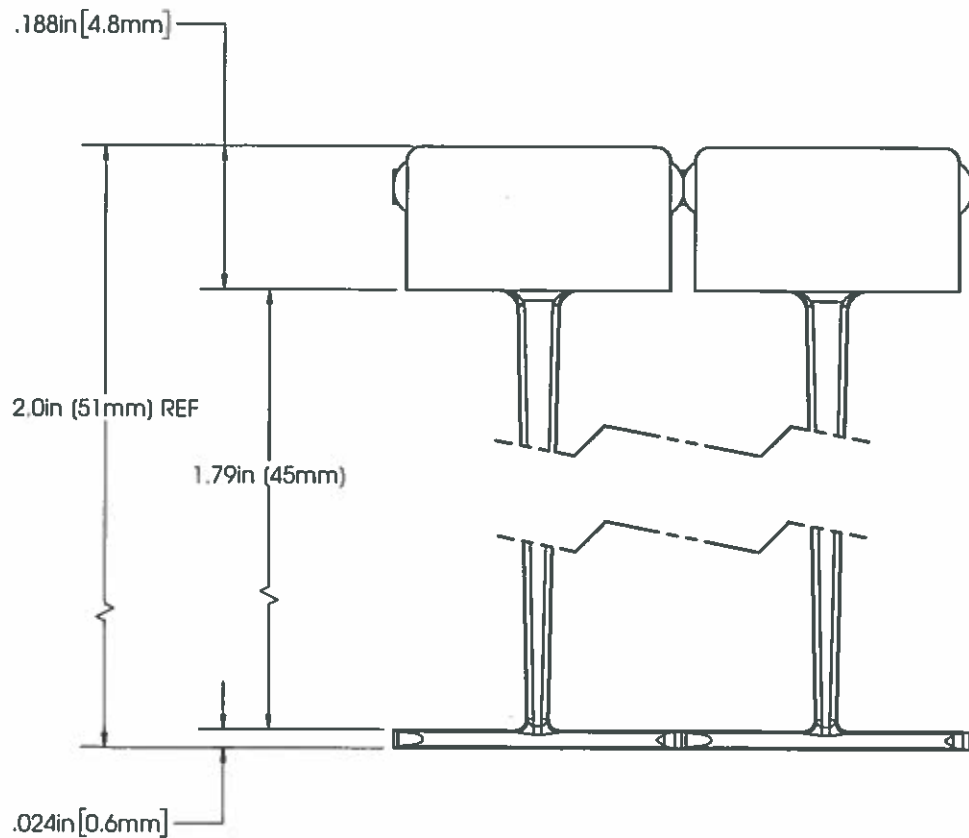

NOT TO SCALE

TENSILE STRENGTH:	2.2 lbf (998 g) MINIMUM	APPROVALS: ENG. APPR. <i>[Signature]</i> 7-26-2017 Q.A. APPR. <i>[Signature]</i> 08/01/2017	AVERY DENNISON		
WEIGHT:	.04 GRAMS/EACH			FASTENER DIVISION FITCHBURG, MA 01420 U.S.A. TEL. 1-800-225-5913 FAX. 978-353-8157	DESCRIPTION SYSTEM 500 FF, STD PADDLE, 2 IN
PACKAGED:	5000/CTN, 50,000/CASE	SPECIFIED TOLERANCES ARE: .XX ± .03 INCHES .X ± .7 mm .XXX ± .010 INCHES .XX ± .25 mm ANGULAR: ± 2°	MATERIAL POLYPROPYLENE	STOCK NO. 16023-0	REV. A
APPLICATION TOOL:	16010-0 - HAND TOOL <small>(CONTACT SALES SPECIALIST FOR ADDITIONAL OPTIONS)</small>		COLOR NATURAL		
ROLL QUANTITY:	500 FASTENERS				

5

4

3

2

1

AVERY DENNISON MARKETING SPECIFICATION

HISTORY

THE SUBJECT MATTER DISCLOSED HEREIN EMBODIES PROPRIETARY INFORMATION WHICH IS THE CONFIDENTIAL PROPERTY OF THE AVERY DENNISON CO. NONE OF WHICH SHALL BE COPIED, REPRODUCED, DISCLOSED TO OTHERS, PUBLISHED OR USED IN WHOLE OR IN PART, FOR ANY PURPOSE OTHER THAN THAT FOR WHICH IT IS BEING MADE AVAILABLE WITHOUT THE EXPRESS ADVANCE WRITTEN PERMISSION OF A DULY AUTHORIZED AGENT OF THE COMPANY. THIS DOCUMENT IS THE PROPERTY OF THE AVERY DENNISON CO. AND IS TO BE RETURNED TO THE COMPANY ON DEMAND.

REV.	DATE	DESCRIPTION
A	05.16.17	PRODUCTION RELEASE

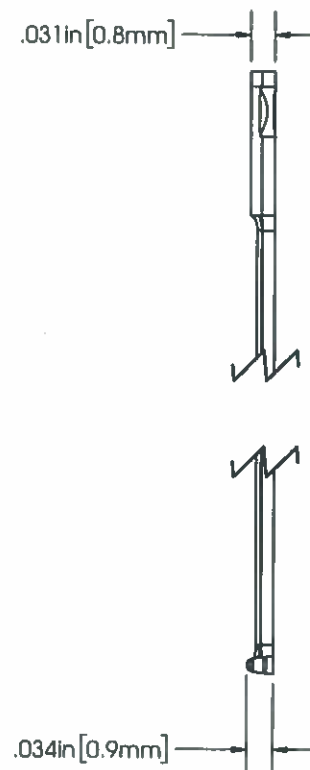
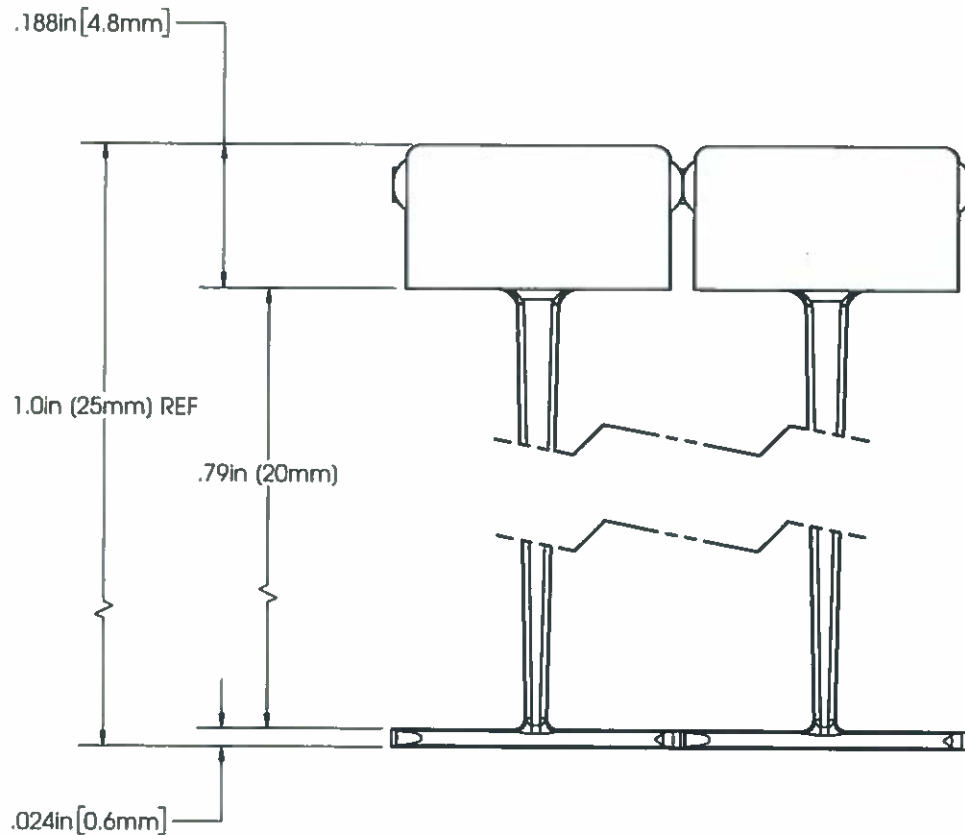

NOT TO SCALE

TENSILE STRENGTH:	2.2 lbf (998 g) MINIMUM	ENG. APPR. <i>[Signature]</i> 7-26-2017	AVERY DENNISON <small>FASTENER DIVISION FITCHBURG, MA 01420 U.S.A. TEL. 1-800-225-5913 FAX. 978-353-8157</small>	DESCRIPTION SYSTEM 500 FF, STD PADDLE, 1 IN
WEIGHT:	.04 GRAMS/EACH	APPROVALS: Q.A. APPR. <i>[Signature]</i> 05/10/2017		
PACKAGED:	5000/CTN. 50,000/CASE	<u>SPECIFIED TOLERANCES ARE:</u>		MATERIAL POLYPROPYLENE
APPLICATION TOOL:	16010-0 - HAND TOOL <small>(CONTACT SALES SPECIALIST FOR ADDITIONAL OPTIONS)</small>	.XX ± .03 INCHES .X ± .7 mm .XXX ± .010 INCHES .XX ± .25 mm ANGULAR: ± 2°		COLOR NATURAL
ROLL QUANTITY	500 FASTENERS			STOCK NO. 16024-0 REV. A

5

4

3

2

1

AVERY DENNISON MARKETING SPECIFICATION

HISTORY		
REV.	DATE	DESCRIPTION
A	05.16.17	PRODUCTION RELEASE

THE SUBJECT MATTER DISCLOSED HEREIN EMBODIES PROPRIETARY INFORMATION WHICH IS THE CONFIDENTIAL PROPERTY OF THE AVERY DENNISON CO. NONE OF WHICH SHALL BE COPIED, REPRODUCED, DISCLOSED TO OTHERS, PUBLISHED OR USED IN WHOLE OR IN PART, FOR ANY PURPOSE OTHER THAN THAT FOR WHICH IT IS BEING MADE AVAILABLE WITHOUT THE EXPRESS ADVANCE WRITTEN PERMISSION OF A DULY AUTHORIZED AGENT OF THE COMPANY. THIS DOCUMENT IS THE PROPERTY OF THE AVERY DENNISON CO. AND IS TO BE RETURNED TO THE COMPANY ON DEMAND.

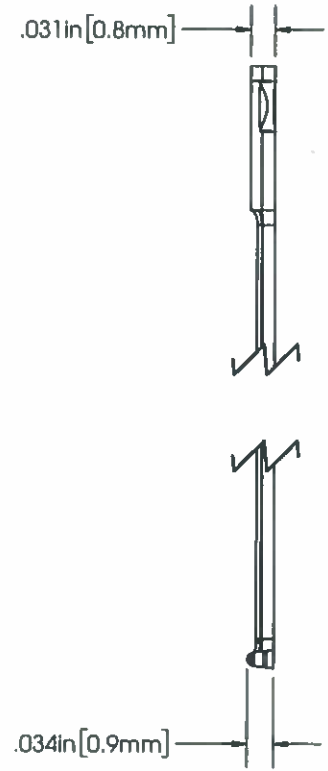
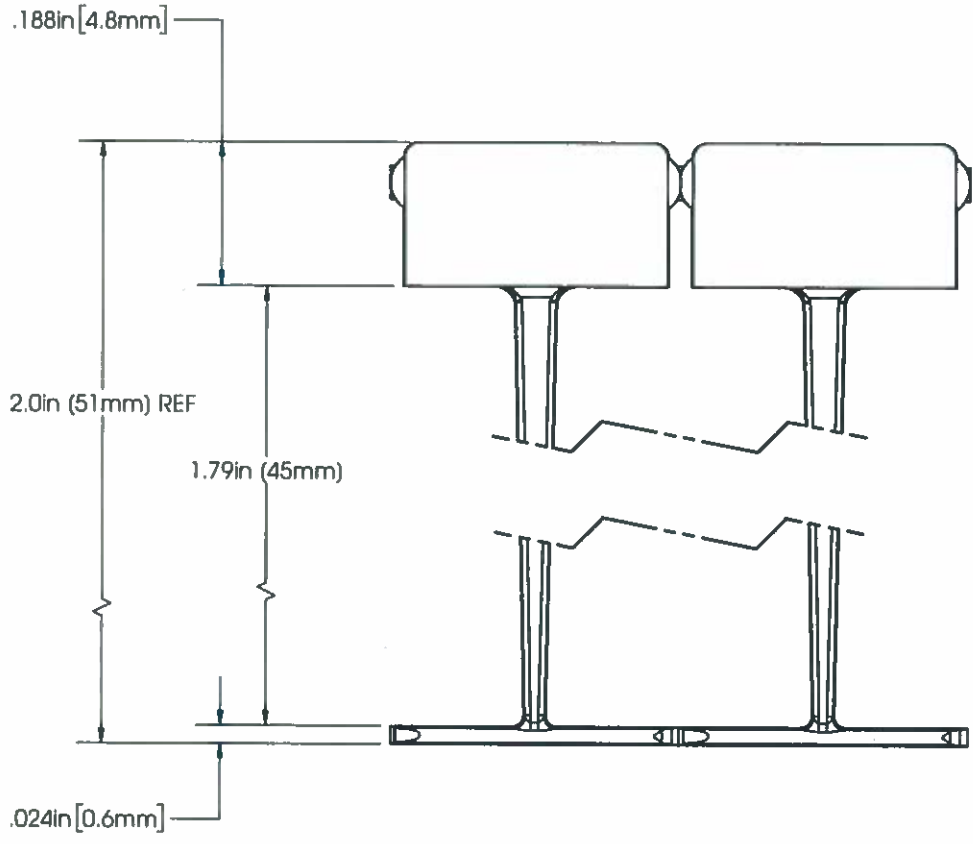

NOT TO SCALE

TENSILE STRENGTH:	4.0 lbf (1814 g) MINIMUM	APPROVALS: ENG. APPR. <i>[Signature]</i> 7-26-2017 Q.A. APPR. <i>[Signature]</i> 08/21/2017	AVERY DENNISON <small>FASTENER DIVISION FITCHBURG, MA 01420 U.S.A. TEL. 1-800-225-5913 FAX. 978-353-8157</small>			
WEIGHT:	.05 GRAMS/EACH					
PACKAGED:	5000/CTN, 50,000/CASE					
APPLICATION TOOL:	16010-0 - HAND TOOL <small>(CONTACT SALES SPECIALIST FOR ADDITIONAL OPTIONS)</small>	SPECIFIED TOLERANCES ARE: .XX ± .03 INCHES .X ± .7 mm .XXX ± .010 INCHES .XX ± .25 mm ANGULAR: ± 2°		MATERIAL NYLON 6 COLOR NATURAL	DESCRIPTION SYSTEM 500 FF, STD PADDLE, 2 IN STOCK NO. 16025-0	
ROLL QUANTITY	500 FASTENERS			REV. A		

5

4

3

2

1

AVERY DENNISON MARKETING SPECIFICATION

HISTORY

THE SUBJECT MATTER DISCLOSED HEREIN EMBODIES PROPRIETARY INFORMATION WHICH IS THE CONFIDENTIAL PROPERTY OF THE AVERY DENNISON CO. NONE OF WHICH SHALL BE COPIED, REPRODUCED, DISCLOSED TO OTHERS, PUBLISHED OR USED IN WHOLE OR IN PART, FOR ANY PURPOSE OTHER THAN THAT FOR WHICH IT IS BEING MADE AVAILABLE WITHOUT THE EXPRESS ADVANCE WRITTEN PERMISSION OF A DULY AUTHORIZED AGENT OF THE COMPANY. THIS DOCUMENT IS THE PROPERTY OF THE AVERY DENNISON CO. AND IS TO BE RETURNED TO THE COMPANY ON DEMAND.

REV.	DATE	DESCRIPTION
A	05.16.17	PRODUCTION RELEASE

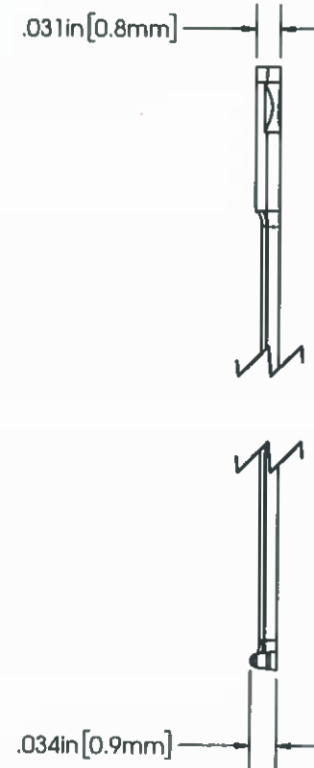
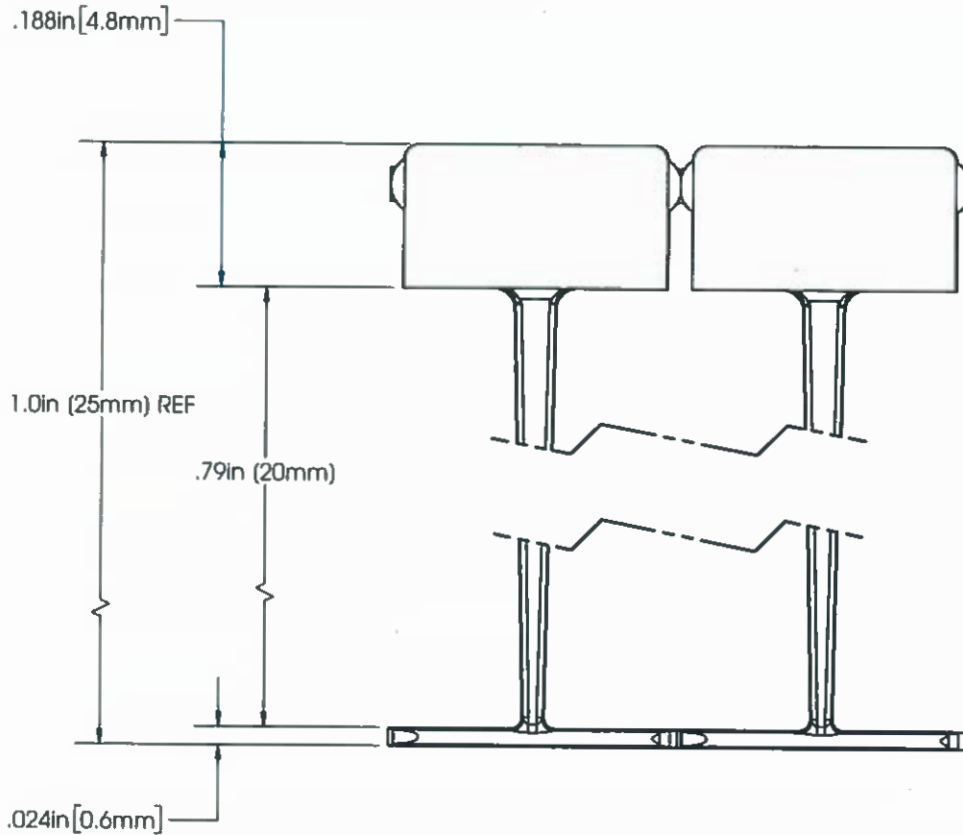

NOT TO SCALE

TENSILE STRENGTH:	4.0 lbf (1814 g) MINIMUM	APPROVALS:	ENG. APPR. <i>[Signature]</i> 7-16-2017	AVERY DENNISON	DESCRIPTION SYSTEM 500 FF, STD PADDLE, 1 IN
WEIGHT:	.05 GRAMS/EACH		Q.A. APPR. <i>[Signature]</i> 08/01/2017		
PACKAGED:	5000/CTN, 50,000/CASE	SPECIFIED TOLERANCES ARE:		MATERIAL	STOCK NO. 16026-0
APPLICATION TOOL:	16010-0 - HAND TOOL <small>(CONTACT SALES SPECIALIST FOR ADDITIONAL OPTIONS)</small>	$.XX \pm .03$ INCHES $.X \pm .7$ mm $.XXX \pm .010$ INCHES $.XX \pm .25$ mm ANGULAR: $\pm 2^\circ$		NYLON 6 COLOR NATURAL	
ROLL QUANTITY	500 FASTENERS				

5

4

3

2

1

AVERY DENNISON MARKETING SPECIFICATION

© 2019 AVERY DENNISON CORPORATION. ALL RIGHTS RESERVED

Released Product

HISTORY

REV.	DATE	DESCRIPTION
A	02.28.20	RELEASE

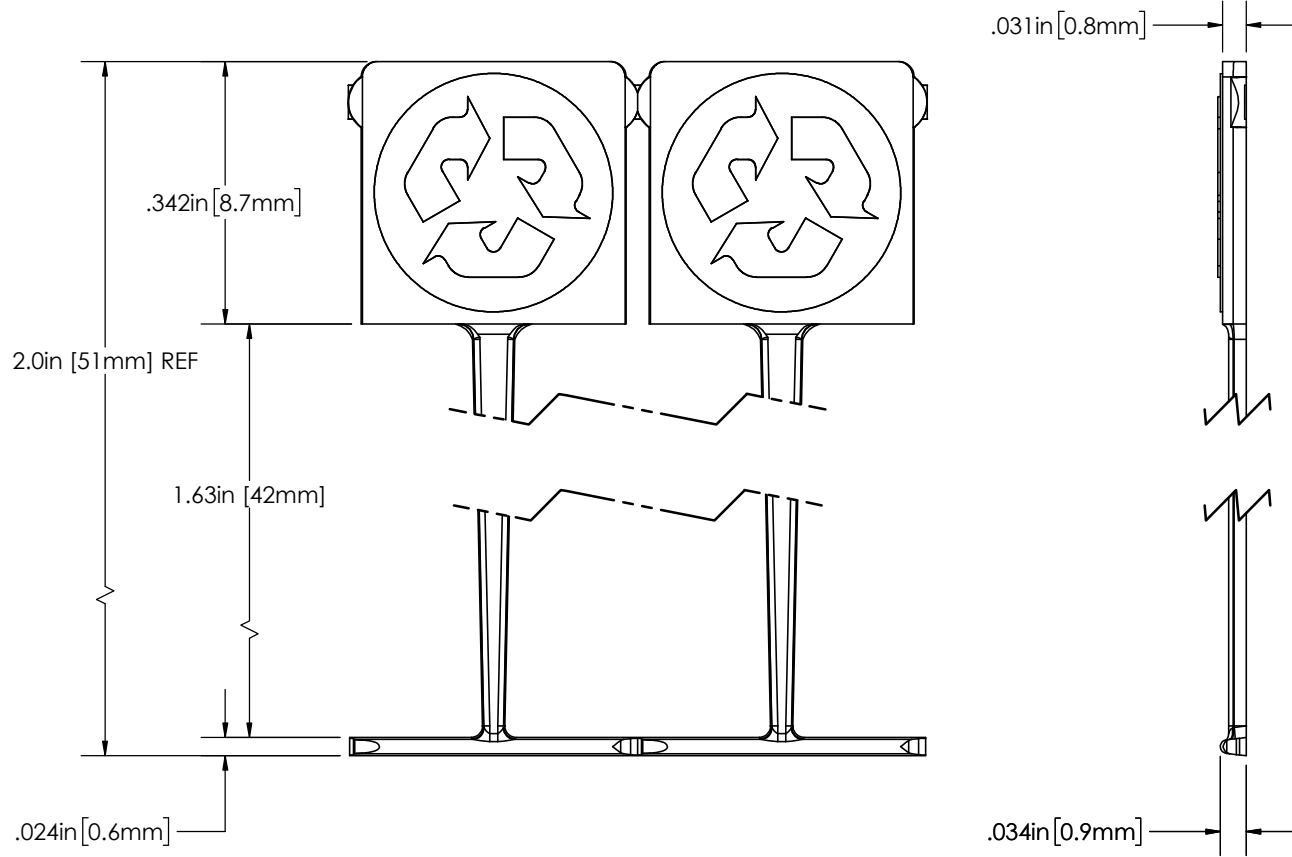

STOCK NUMBER	REV	COLOR
17041-0	A	NATURAL
17042-0	A	BLACK
17043-0	A	WHITE

NOT TO SCALE

TENSILE STRENGTH:	2.5 lbf [1134g MINIMUM]	APPROVALS:	ENG. APPR.	<i>Dave Schuttler 02.28.20</i>		FASTENER DIVISION FITCHBURG, MA 01420 U.S.A. TEL. 1-800-225-5913 FAX. 978-353-8157
WEIGHT:	.09 GRAMS/EACH		Q.A. APPR.	<i>Rick Estano 02.28.20</i>		
PACKAGED:	5000/CTN, 50,000/CASE	SPECIFIED TOLERANCES ARE:	MATERIAL	>/= 90% rPET	DESCRIPTION	SYSTEM 500 FF, rPET
APPLICATION TOOL:	16010-0 - HAND TOOL			</=10% PE & COLOR CONC		
ROLL QUANTITY:	500 FASTENERS	.XX ± .03 INCHES .X ± .7 mm	COLOR	SEE TABLE	STOCK NO.	SEE TABLE
	(CONTACT SALES SPECIALIST FOR ADDITIONAL OPTIONS)	.XXX ± .010 INCHES .XX ± .25 mm			REV	AA
		ANGULAR: ± 2°				

5

↑

4

3

2

1

AVERY DENNISON CORPORATION

FASTENER SOLUTIONS

GRAPHIC FASTENING SYSTEM – FINE FABRIC

*** ± 0.7 mm

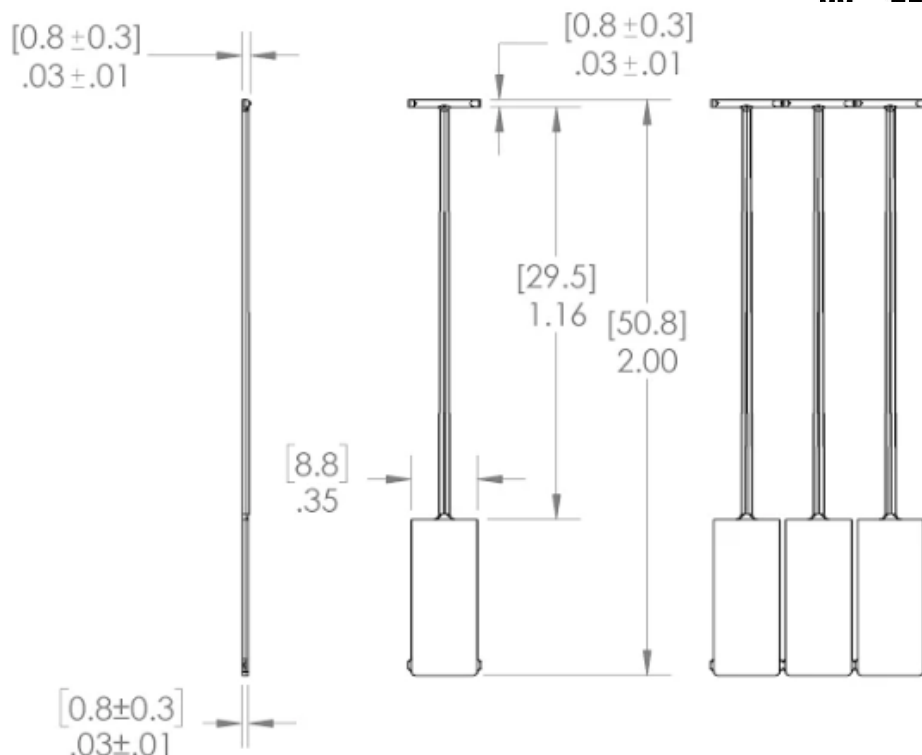

Applied Min.Tensile Strength:	2.0 lbf [0.9 kgf] minimum
Material:	PP – Polypropylene (fastener and image)
Color:	Natural
Weight:	.131 grams each
Roll Quantity:	500
Packaged:	5,000/carton, 50,000/case
Application Tools:	System 500™ Fine Fabric Hand tool #16010-0 Contact your Account Executive for other options



FASTENER SOLUTIONS
 FITCHBURG, MA. USA 01420
 TEL 1-800-225-5913
 FAX 1-800-848-2169

TOLERANCES:
 INCH = +/- .030in
 MM = +/- 0.7mm

NOT TO SCALE

2" (51mm) Fine Fabric Graphic Fastener	
PART NO.	REV

QA APPROVAL:
 SIGNATURE: _____
 PRINTED NAME: _____

AVERY DENNISON CORPORATION FASTENER SOLUTIONS

GRAPHIC FASTENING SYSTEM – FINE FABRIC

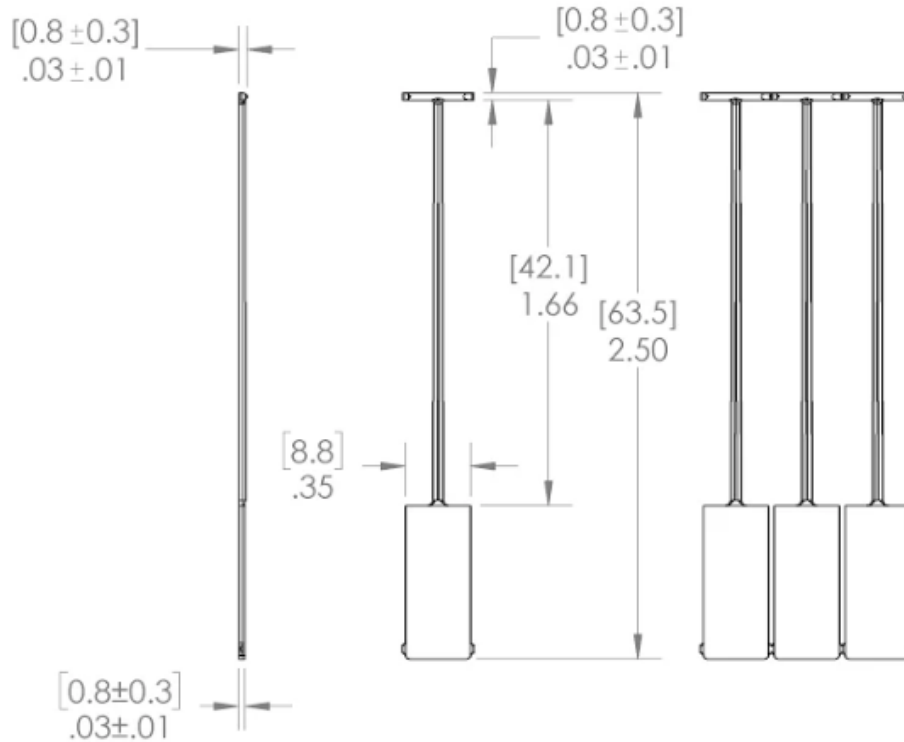

Applied Min.Tensile Strength:	2.0 lbf [0.9 kgf] minimum
Material:	PP – Polypropylene (fastener and image)
Color:	Natural
Weight:	.131 grams each
Roll Quantity:	500
Packaged:	5,000/carton, 50,000/case
Application Tools:	System 500™ Fine Fabric Hand tool #16010-0 Contact your Account Executive for other options



FASTENER SOLUTIONS
FITCHBURG, MA. USA 01420
TEL 1-800-225-5913
FAX 1-800-848-2169

TOLERANCES:
INCH = +/- .030in
MM = +/- 0.7mm

DESCRIPTION: 2.5" (63.5mm) Fine Fabric Graphic Fastener		QA APPROVAL: SIGNATURE: _____	
PART NO.	REV	PRINTED NAME: _____	

AVERY DENNISON CORPORATION

FASTENER SOLUTIONS

GRAPHIC FASTENING SYSTEM – FINE FABRIC

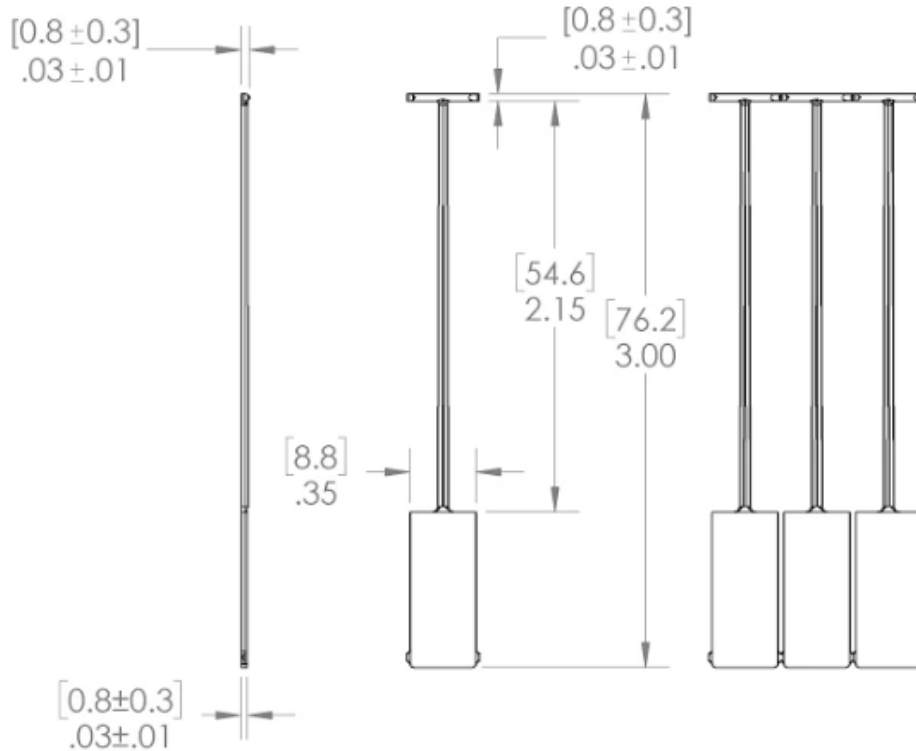

Applied Min.Tensile Strength:	2.0 lbf [0.9 kgf] minimum
Material:	PP – Polypropylene (fastener and image)
Color:	Natural
Weight:	.131 grams each
Roll Quantity:	500
Packaged:	5,000/carton, 50,000/case
Application Tools:	System 500™ Fine Fabric Hand tool #16010-0 Contact your Account Executive for other options



FASTENER SOLUTIONS
FITCHBURG, MA. USA 01420
TEL 1-800-225-5913
FAX 1-800-848-2169

TOLERANCES:
INCH = +/- .030in
[MM] = +/- 0.7mm

DESCRIPTION: 3" (76mm) Fine Fabric Graphic Fastener		QA APPROVAL:	
PART NO.		SIGNATURE: _____	
REV		PRINTED NAME: _____	

AVERY DENNISON CORPORATION

FASTENER SOLUTIONS

GRAPHIC FASTENING SYSTEM – FINE FABRIC

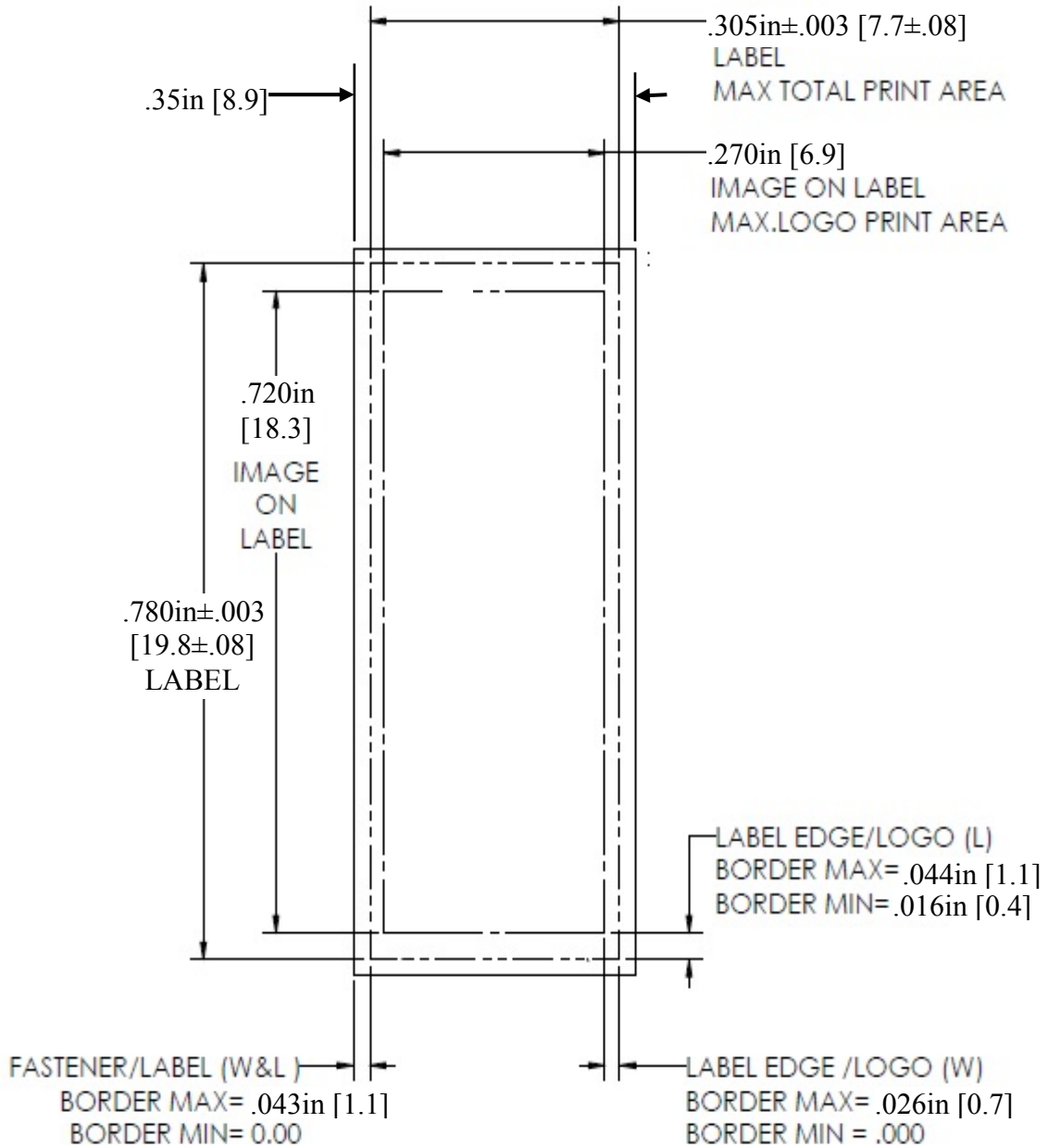

PRINT AREA DETAIL